

THIS DRAWING IS UNPUBLISHED. RELEASED FOR PUBLICATION AUGUST, 2005.
 © COPYRIGHT 2005 BY TYCO ELECTRONICS CORPORATION. ALL RIGHTS RESERVED.

LOC	DIST	REVISIONS					
		P	LTR	DESCRIPTION	DATE	DWN	APVD
E	B	B		ECR-07-024341	12OCT07	JMS	FWK

- NOTES:
- 1. SINGLE PACK IN ACCORDANCE WITH AMP SPEC 107-3275
 - 2. 50 TRAY PACK IN ACCORDANCE WITH AMP SPEC 107-3275
 - 3. Au PLATING OVER Ni PLATING OVER Cu PLATING
 - 4. Ni PLATING OVER Cu PLATING
 - 5. TIN PLATING
 - 6. RECOMMENDED SELF-TAPPING SCREW 221108-4
 - 7. RECOMMENDED MOUNT NUT 1-1634816-0
 - 8. RECOMMENDED LOCKWASHER 1-1634817-0
 - 9. CHARACTERISTICS

FREQUENCY RANGE:	DC - 4GHz
NOMINAL IMPEDANCE:	50 OHMS
WORKING VOLTAGE:	500V RMS
INSULATION RESISTANCE:	5000 MOHMS
DIELECTRIC WITHSTAND VOLTAGE:	1500V RMS
CONTACT RESISTANCE:	
CENTRE CONTACT:	1.5 mOHMS
OUTER CONTACT:	0.2 mOHMS
 - 10. MECHANICAL CHARACTERISTICS

DURABILITY:	50 CYCLES
-------------	-----------
 - 11. FOR TECHNICAL DATA REFER TO YOUR LOCAL TYCO ELECTRONICS SALES OFFICE
 - 12. ALL DIMENSIONS ARE NOMINAL FOR REFERENCE ONLY UNLESS OTHERWISE STATED

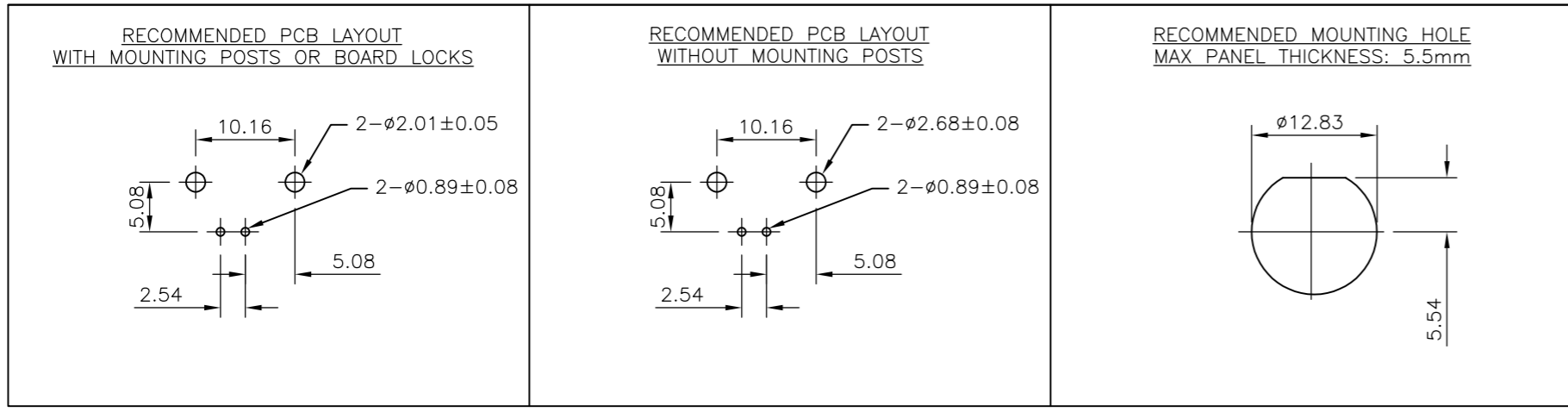
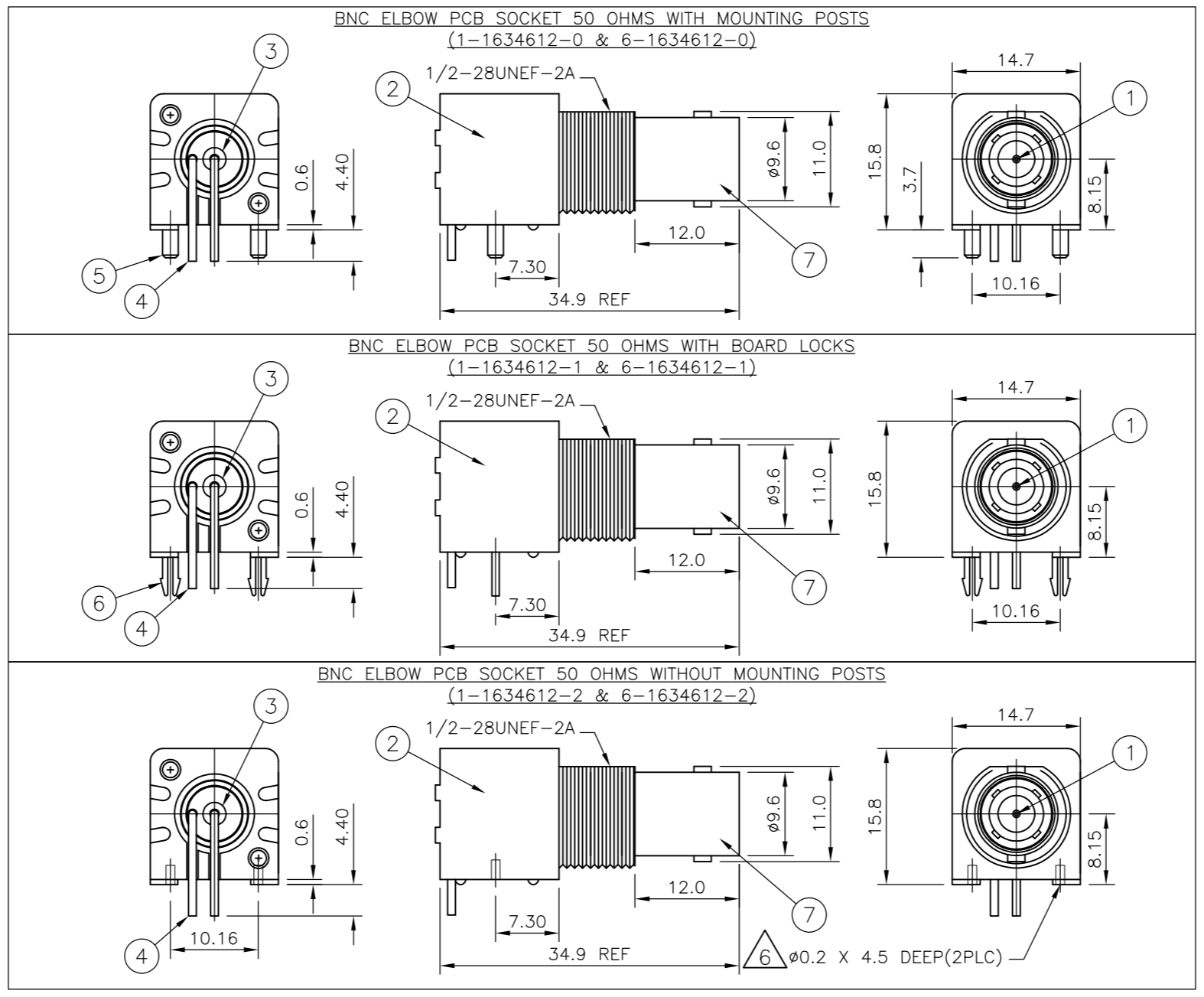

QTY	DESCRIPTION	MATERIAL	ITEM					
1	ZINC DIECAST	△ BODY	7					
2	BRASS	△ BOARD LOCK	6					
2	BRASS	△ MOUNTING POST	5					
1	BRASS	△ SOLDER TAIL	4					
1	PE-606	INSULATOR	3					
1	PBT BLACK	HOUSING	2					
1	BRASS	△ CONTACT	1					
6--2	1--2	6--1	1--1	6--0	1--0	MATERIAL	DESCRIPTION	ITEM

THIS DRAWING IS A CONTROLLED DOCUMENT.

DWN	J.SANDWELL	15AUG05
CHK	S.PARLOW	15AUG05
APVD	F.WHEELER-KING	15AUG05
PRODUCT SPEC	108-3435	
APPLICATION SPEC	N/A	
MATERIAL	SEE TABLE	
FINISH	SEE TABLE	
WEIGHT	-	
CUSTOMER DRAWING		

Tyco Electronics Corporation
Bideford, UK, EX39 4HE

**BNC HIGH PROFILE R/A INSULATED PCB SOCKET
50 OHM BLACK**

SIZE	CAGE CODE	DRAWING NO	RESTRICTED TO
A2	00779	C=1634612	-
SCALE	SHEET	OF	REV
NTS	1	1	B